

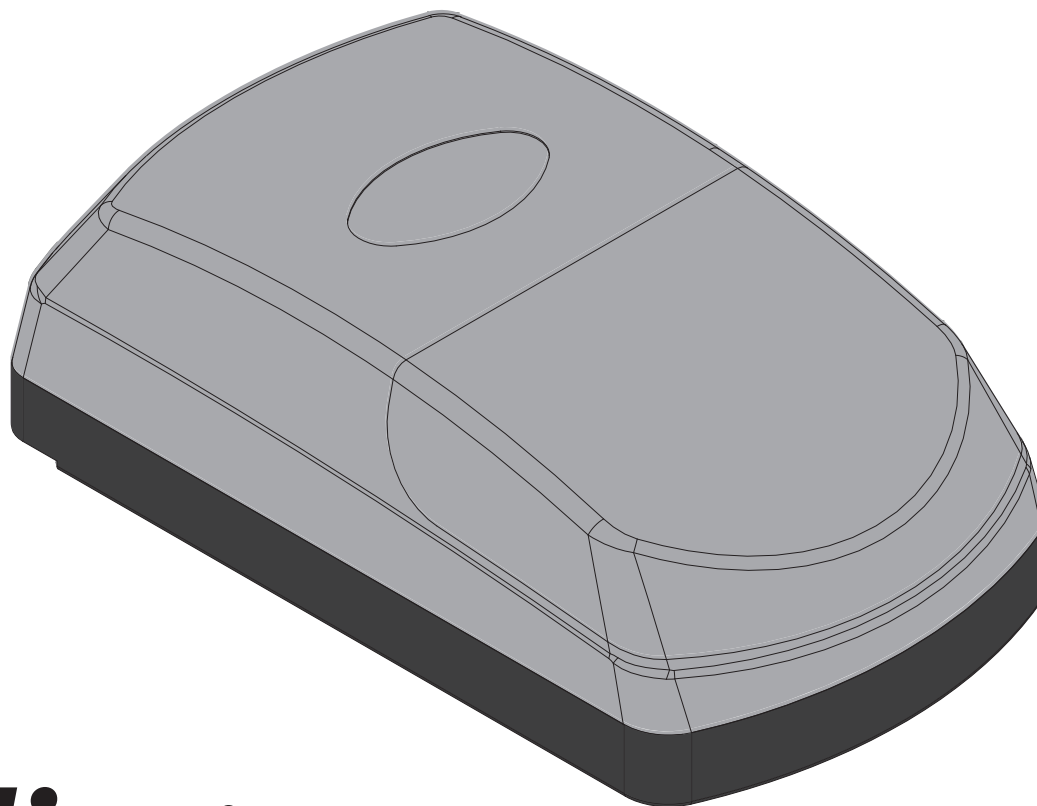

KVM25

USER'S AND INSTALLER'S MANUAL









00. CONTENTS

INDEX

01. SAFETY INSTRUCTIONS	
STANDARDS TO FOLLOW	1B
02. THE PACKAGE	
INSIDE THE PACKAGE	4A
03. THE AUTOMATISM	
LOCK/UNLOCK	4B
TECHNICAL SPECIFICATIONS	5A
04. INSTALLATION	
PRE-INSTALLATION INFO	5B
AUTOMATISM INSTALLATION	6A
INSTALLATION MAP	7B
GROUND WIRE CONNECTION	7B
05. PROGRAMMING	
PROGRAMMING THE LIMIT SWITCHES	8A

01. SAFETY INSTRUCTIONS

	This product is certified in accordance with European Community (EC) safety standards.
	This product complies with Directive 2011/65/EU of the European Parliament and of the Council, of 8 June 2011, on the restriction of the use of certain hazardous substances in electrical and electronic equipment and with Delegated Directive (EU) 2015/863 from Commission.
	(Applicable in countries with recycling systems). This marking on the product or literature indicates that the product and electronic accessories (eg. Charger, USB cable, electronic material, controls, etc.) should not be disposed of as other household waste at the end of its useful life. To avoid possible harm to the environment or human health resulting from the uncontrolled disposal of waste, separate these items from other types of waste and recycle them responsibly to promote the sustainable reuse of material resources. Home users should contact the dealer where they purchased this product or the National Environment Agency for details on where and how they can take these items for environmentally safe recycling. Business users should contact their vendor and check the terms and conditions of the purchase agreement. This product and its electronic accessories should not be mixed with other commercial waste.
	This marking indicates that batteries should not be discarded like other household waste at the end of their useful life. Batteries must be delivered to selective collection points for recycling.
	The different types of packaging (cardboard, plastic, etc.) must be subject to selective collection for recycling. Separate packaging and recycle it responsibly.
	This marking indicates that the product and electronic accessories (eg. charger, USB cable, electronic material, controls, etc.) are susceptible to electric shock by direct or indirect contact with electricity. Be cautious when handling the product and observe all safety procedures in this manual.

01. SAFETY INSTRUCTIONS

GENERAL WARNINGS

- This manual contains very important safety and usage information. Read all instructions carefully before beginning the installation/usage procedures and keep this manual in a safe place that it can be consulted whenever necessary.
- This product is intended for use only as described in this manual. Any other enforcement or operation that is not mentioned is expressly prohibited, as it may damage the product and put people at risk causing serious injuries.
- This manual is intended firstly for specialized technicians, and does not invalidate the user's responsibility to read the "User Norms" section in order to ensure the correct functioning of the product.
- The installation and repair of this product may be done by qualified and specialized technicians, to assure every procedure are carried out in accordance with applicable rules and norms. Nonprofessional and inexperienced users are expressly prohibited of taking any action, unless explicitly requested by specialized technicians to do so.
- Installations must be frequently inspected for unbalance and the wear signals of the cables, springs, hinges, wheels, supports and other mechanical assembly parts.
- Do not use the product if it is necessary repair or adjustment is required.
- When performing maintenance, cleaning and replacement of parts, the product must be disconnected from power supply. Also including any operation that requires opening the product cover.
- The use, cleaning and maintenance of this product may be carried out by any persons aged eight years old and over and persons whose physical, sensorial or mental capacities are lower, or by persons without any knowledge of the product, provided that these are supervision and instructions given by persons with experienced in terms of usage of the product in a safe manner and who understands the risks and dangers involved.

- Children shouldn't play with the product or opening devices to avoid the motorized door or gate from being triggered involuntarily.
- If the power cable is damaged, it must be replaced by the manufacturer, after-sales service or similarly qualified personnel to avoid danger.
- The device must be disconnected from the electrical network when removing the battery.
- Ensure that blocking is avoided between the actuated part and its fixed parts due to the opening movement of the actuated part.

WARNINGS FOR TECHNICIANS

- Before beginning the installation procedures, make sure that you have all the devices and materials necessary to complete the installation of the product.
- You should note your Protection Index (IP) and operating temperature to ensure that is suitable for the installation site.
- Provide the manual of the product to the user and let them know how to handle it in an emergency.
- If the automatism is installed on a gate with a pedestrian door, a door locking mechanism must be installed while the gate is in motion.
- Do not install the product "upside down" or supported by elements do not support its weight. If necessary, add brackets at strategic points to ensure the safety of the automatism.
- Do not install the product in explosive site.
- Safety devices must protect the possible crushing, cutting, transport and danger areas of the motorized door or gate.
- Verify that the elements to be automated (gates, door, windows, blinds, etc.) are in perfect function, aligned and level. Also verify if the necessary mechanical stops are in the appropriate places.
- The control board must be installed on a safe place of any fluid (rain, moisture, etc.), dust and pests.
- You must route the various electrical cables through protective tubes, to protect them against mechanical exertions, essentially on

01. SAFETY INSTRUCTIONS

the power supply cable. Please note that all the cables must enter the control board from the bottom.

- If the automatism is to be installed at a height of more than 2,5m from the ground or other level of access, the minimum safety and health requirements for the use of work equipment workers at the work of Directive 2009/104/CE of European Parliament and of the Council of 16 September 2009.
- Attach the permanent label for the manual release as close as possible to the release mechanism.
- Disconnect means, such as a switch or circuit breaker on the electrical panel, must be provided on the product's fixed power supply leads in accordance with the installation rules.
- If the product to be installed requires power supply of 230Vac or 110Vac, ensure that connection is to an electrical panel with ground connection.
- The product is only powered by low voltage safety with control board (only at 24V motors).
- Parts/products weighing more than 20 kg must be handled with special care due to the risk of injury. It is recommended to use suitable auxiliary systems for moving or lifting heavy objects.
- Pay special attention to the danger of falling objects or uncontrolled movement of doors/gates during the installation or operation of this product.

WARNINGS FOR USERS

- Keep this manual in a safe place to be consulted whenever necessary.
- If the product has contact with fluids without being prepared, it must immediately disconnect from the power supply to avoid short circuits, and consult a specialized technician.
- Ensure that technician has provided you the product manual and informed you how to handle the product in an emergency.
- If the system requires any repair or modification, unlock the automatism, turn off the power and do not use it until all safety

conditions have been met.

- In the event of tripping of circuits breakers or fuse failure, locate the malfunction and solve it before resetting the circuit breaker or replacing the fuse. If the malfunction is not repairable by consult this manual, contact a technician.
- Keep the operation area of the motorized gate free while the gate in in motion, and do not create strength to the gate movement.
- Do not perform any operation on mechanical elements or hinges if the product is in motion.

RESPONSABILITY

- Supplier disclaims any liability if:
 - Product failure or deformation result from improper installation use or maintenance!
 - Safety norms are not followed in the installation, use and maintenance of the product.
 - Instructions in this manual are not followed.
 - Damaged is caused by unauthorized modifications
 - In these cases, the warranty is voided.

MOTORLINE ELECTROCELOS SA.

Travessa do Sobreiro, nº29
4755-474 Rio Côvo (Santa Eugénia)
Barcelos, Portugal

SYMBOLS LEGEND:



• Important safety notices



• Useful information



• Programming information



• Potentiometer information



• Connectors information



• Buttons information

02. THE PACKAGE

INSIDE THE PACKAGE

Inside the package you will find the following components:

- 1 • 01 automatism KVM25
- 2 • 01 maneuver board
- 3 • 02 four channel transmitters FALK
- 4 • 01 mounting plate
- 5 • 01 chain
- 6 • 01 pinion for Ø25mm shaft
- 7 • 01 bearing bracket
- 8 • 04 fixing screws
- 9 • 01 unlocking cord
- 10 • 01 user manual

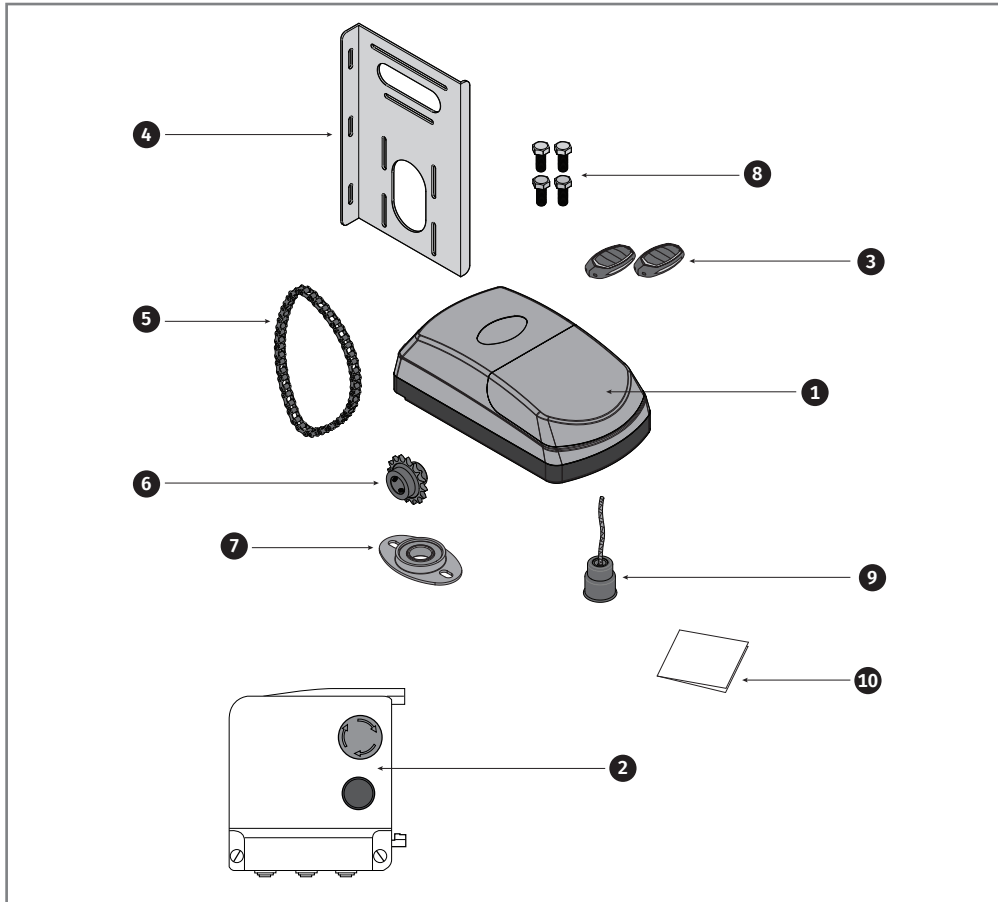

03. THE AUTOMATISM

LOCK/UNLOCK

The automatism unlock function allows the user to open and close the gate manually, without having to remove the motor from the installation site. This functionality is specially important in emergency cases and/or power cuts.

To lock or unlock the automatism just pull down the lever as shown in the following image. The lever has a spring that will bring it up to the starting point. Each time you pull the lever down and rise completely, you will unlock or lock the automatism. When pulling down, a small sound of gears engaging means that the lock/unlock was successfully performed.

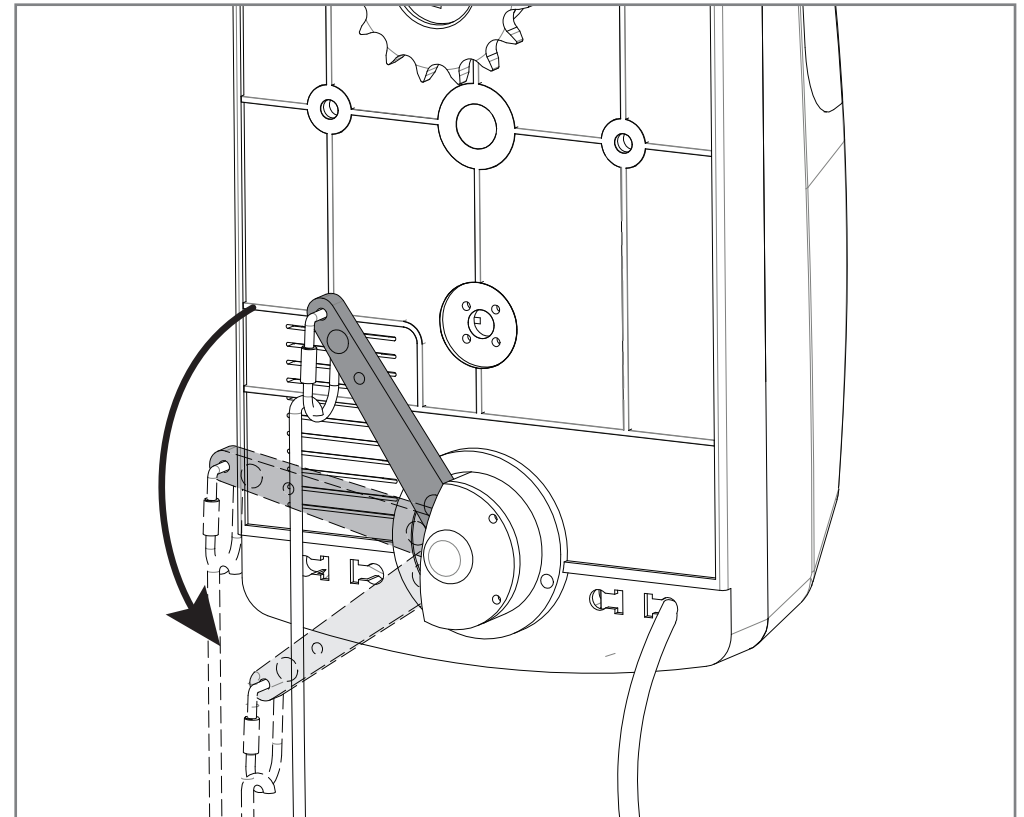

03. THE AUTOMATISM

TECHNICAL SPECIFICATIONS

KVM25 specifications are as follow:

• Power Supply	AC 230V 50/60Hz
• Power	80W
• Current	8A
• RPM	20 RPM
• Noise level	<50dB
• Force	13Nm
• Operating temperatures	-25°C to 55°C
• Transformer	100W
• Protection class	IP20
• Work Rate	30 cycles/h
• Fuses	220V 1A - 24V 10A

KVM25 dimensions are the following:

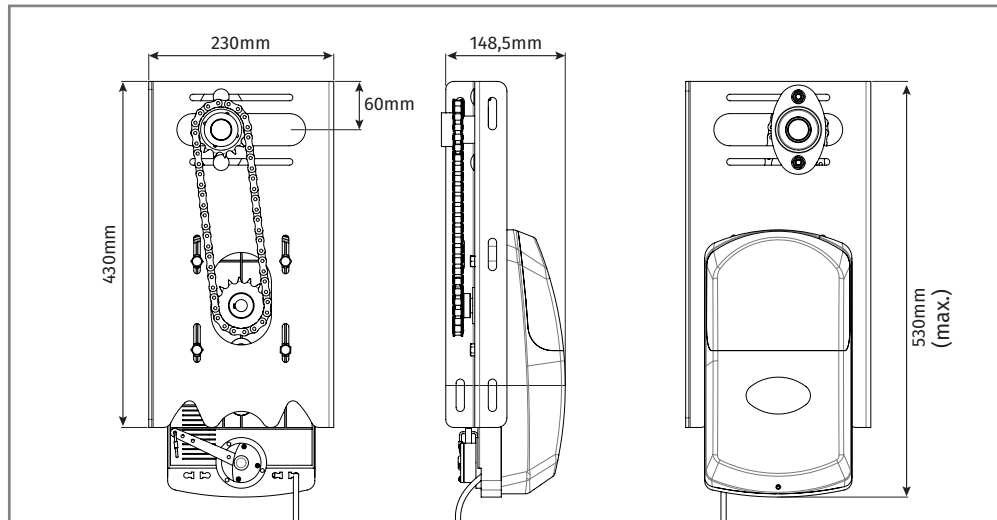

04. INSTALLATION

PRE-INSTALLATION INFO

For a proper installation and a durable performance of KVM25, be aware of the following parameters:

- Please read all steps of this manual at least once, so that you know the full process before starting the real assembling.
- This equipment can only be installed on sectional doors with a maximum area of 12m².
- Please make sure that the door's structure is solid and in good conditions to be automated.
- Make sure that the sectional door has no mechanical anomalies, they may affect the automatism's durability .
- To check if the door is in good condition for the motor to be installed, manually raise it to 800mm, 1600mm and 2000mm from the floor and drop it. The door must remain suspended in that position or going down very slightly. If this does not happen, check the springs condition.
- Check the surrounding space. Carefully evaluate potential dangers that can cause physical damage and possible contact with bugs, infiltrations or others.
- Please make sure that the automatism will be connected to a 230V power supply, protected with earth wire.
- Please check if there is appropriate electronic protection against short-circuits/current peaks, and earth wire on the main electric board.
- Be careful in case of manually operating the control board. The incorrect usage can damage some sensible electronic components.
- Check if you have all the necessary material ready for the installation.
- Check all safety devices to install. This will ensure that unexpected accidents won't happen.



It is very important that before installation, make sure the springs are adjusted according to the door's weight!

04. INSTALLATION

AUTOMATISM INSTALLATION

In the illustrated diagrams below and on the following page, are represented the procedures for proper installation of the motor KVM25.

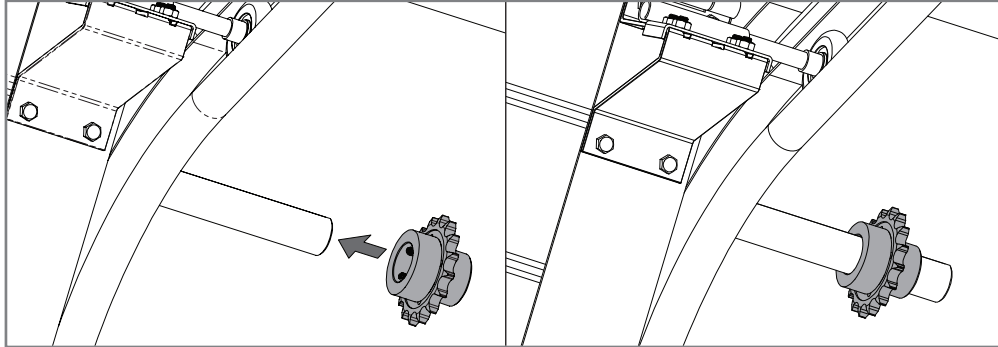

01 - Place the pinion on the $\varnothing 25$ mm spring's shaft of the sectional door.

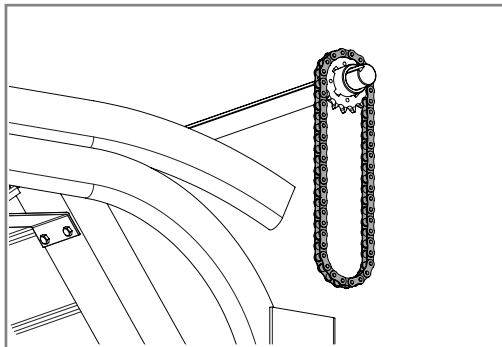

02 - Place the chain over the pinion leaving it hanged.

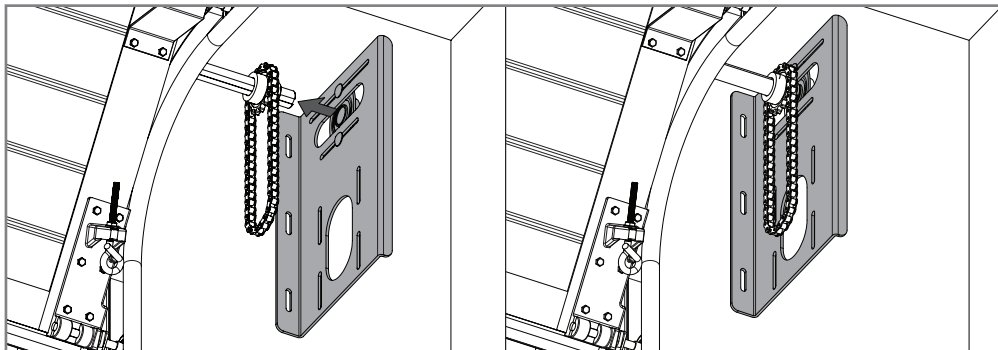

03 - Pass the $\varnothing 25$ mm shaft through the bearing on the support plate.

04. INSTALLATION

AUTOMATISM INSTALLATION

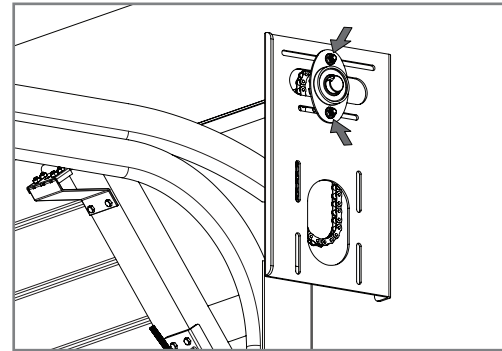

04 - Slightly loosen the bearing bracket's screws (left), to be able to move it sideways.

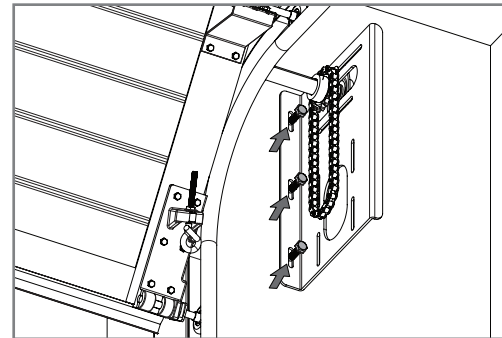

05 - Pull the metal plate to the wall and secure with the screws.
After fixing the plate, tighten the bearing bracket's screws back to fix it too.

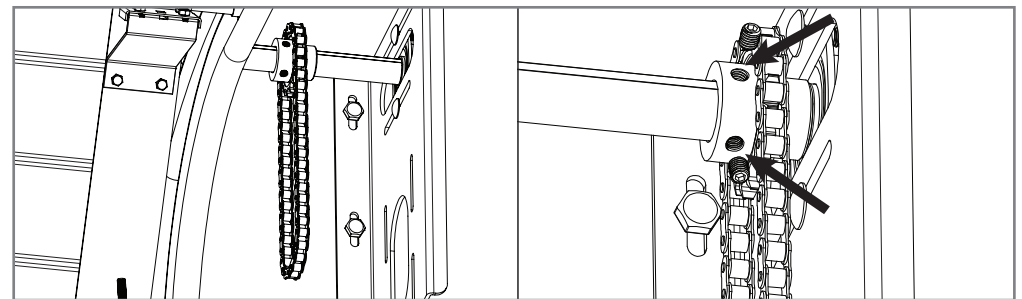

06 - Pull the pinion to the bearing and tighten the two bolts to secure the pinion to the shaft.



It is very important that these quotas are respected! Only in this way the correct functioning and durability of automatism can be assured!

04. INSTALLATION

AUTOMATISM INSTALLATION

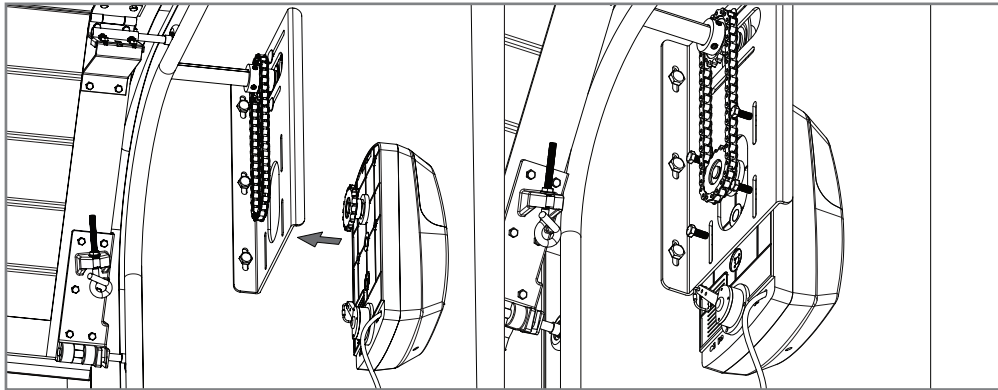

07 - Place the automatism on the support plate (left), and assemble the chain on the motor's pinion as you can see on the right image. Place the screws on the motor in order to support it on the metal plate, without tightening them completely, so that you are able to adjust the automatism.

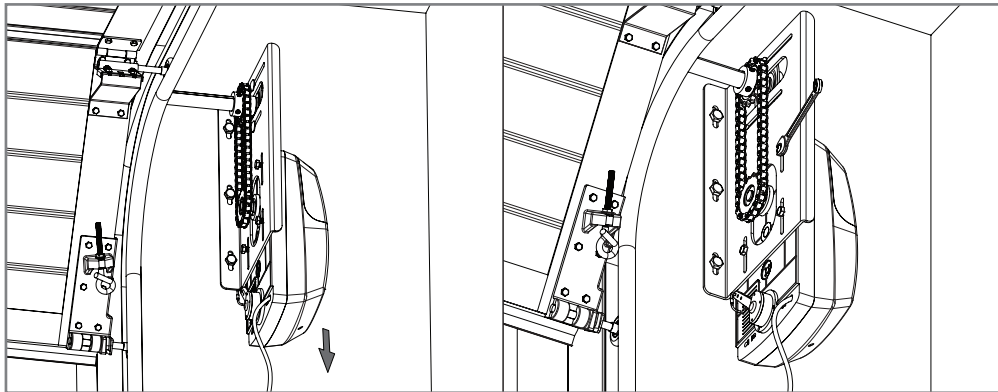

08 - With the bolts still loose, pull the engine down in order to tighten the chain. While pulling down, fasten the 4 motor bolts to secure it on the support plate. The automatism is now installed.

04. INSTALLATION

INSTALLATION MAP

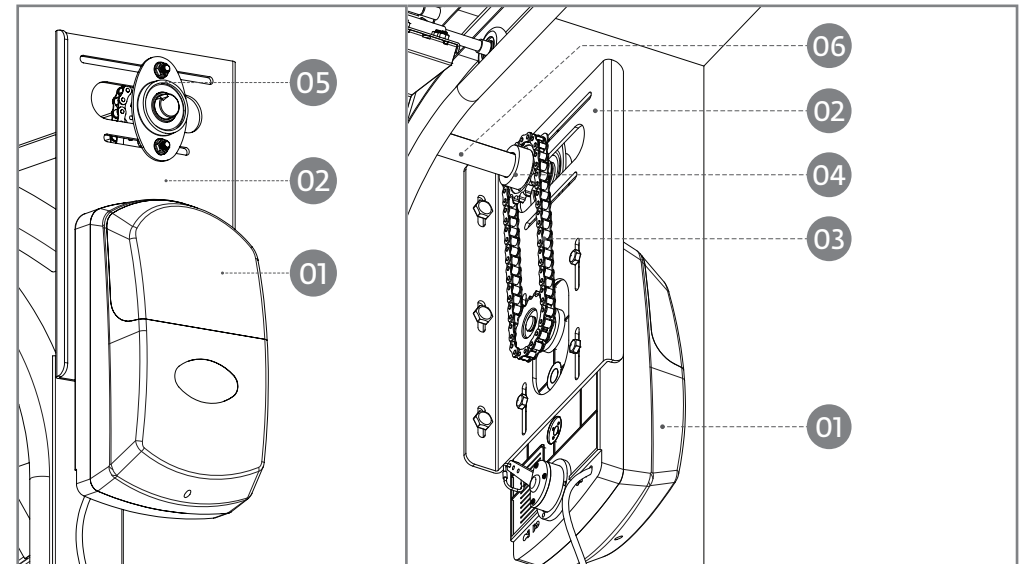

LEGEND: 01 • motor KVM25
02 • support plate
03 • chain

04 • pinion for $\varnothing 25$ mm shaft
05 • bearing bracket
06 • $\varnothing 25$ mm sectional door's shaft

GROUND WIRE CONNECTION

Ground wire connection area.

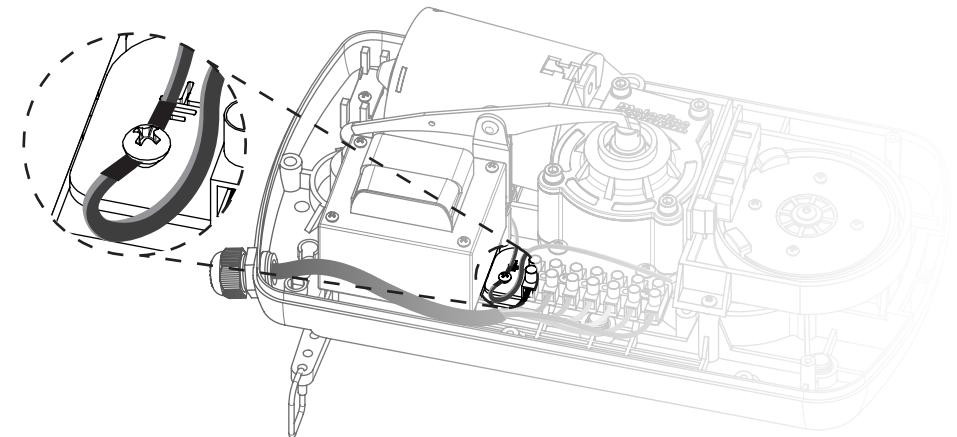

05. PROGRAMMING

PROGRAMMING LIMIT SWITCHES

In the illustrated diagrams below and on the following page are represented the procedures for proper programming of the motor KVM25 limit switches, once installed on the gate.

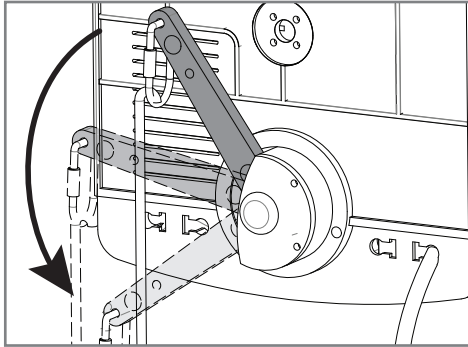

01 - Unlock the motor, pulling the lever down. You will hear a little click when pulling down, and then you must let the lever go up.

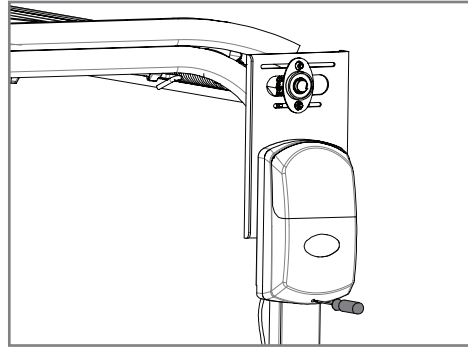

02 - Open the automatism cover with a screwdriver and connect the motor to a power source at 230V.

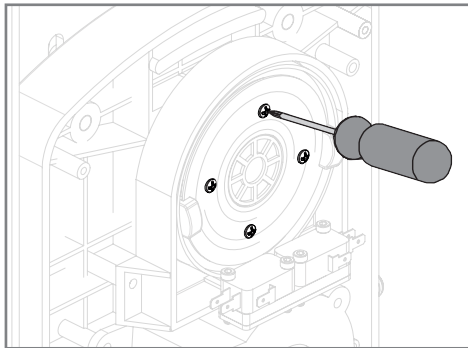

03 - Slightly loosen the 4 screws of the magnetic actuator.

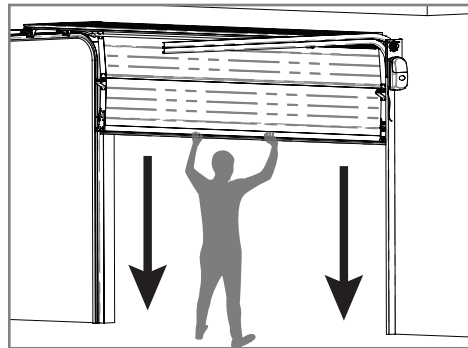

04 - Manually pull the door into the closed position.



It is very important that these quotas are respected! Only in this way the correct functioning and durability of automatism can be assured!

05. PROGRAMMING

PROGRAMMING LIMIT SWITCHES

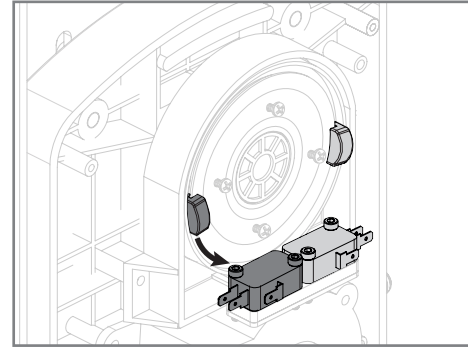

05 - Move the plastic piece until hear a click from the micro.

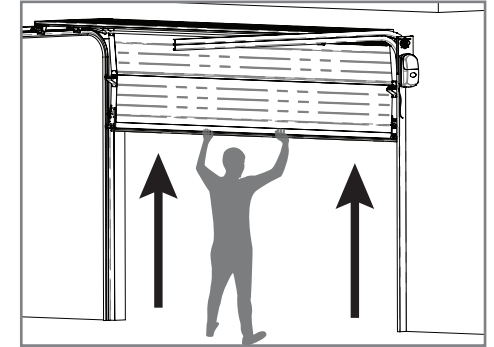

06 - Manually move the door to the open position.

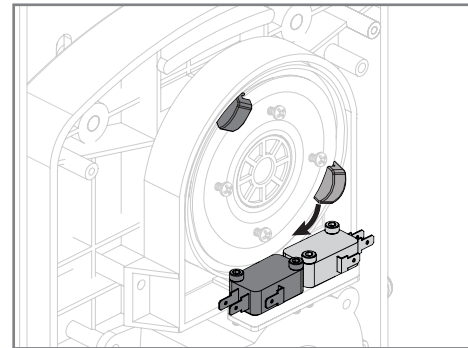

07 - Move the plastic piece until hear a click from the micro. Now tighten the 4 screws of the magnetic actuator.

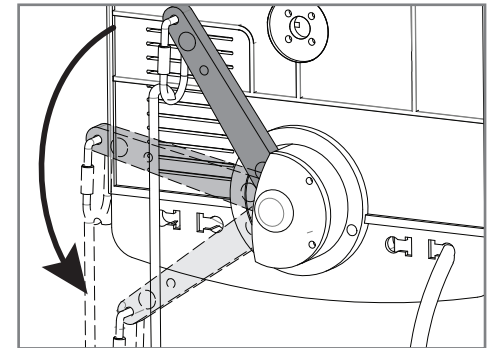

08 - Lock the motor and test the door opening and closing using either the "PUSH" button on the control board or the transmitter. If necessary, repeat the previous steps, from the image 03, to better tune the limit switches.